

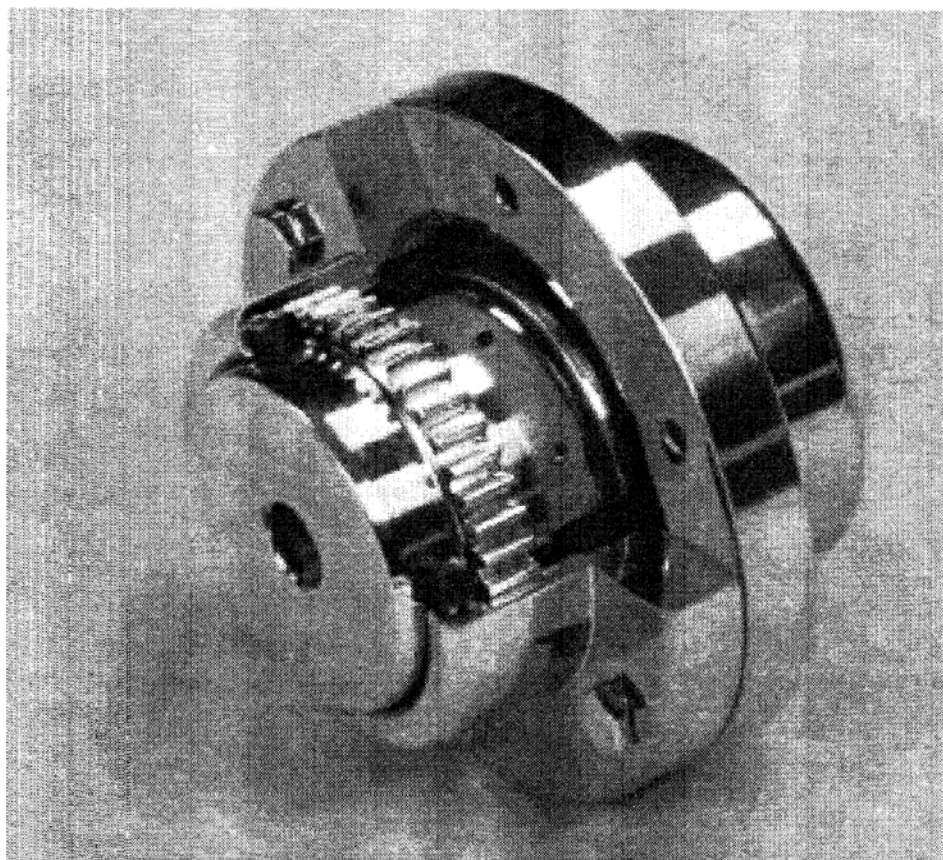

# **F & MXB Series Gear Coupling Installation and Maintenance Instructions**



**TB WOOD'S INCORPORATED  
Chambersburg, PA**

## F and MXB Coupling Installation And Maintenance Instructions

### Installation:

1. Be sure all components are present and free of burrs or chips.
2. Be certain the rubber seals are properly seated in the flanges. Coat these with a light film of grease.
3. Place the sleeves over the shaft ends. Care should be taken not to damage the rubber seals.
4. Install the hubs on the respective shafts. Interference fit hubs often require heating the hubs in hot oil or an oven to 320° F prior to installation. The hub faces should be flush with the shaft ends.
5. Locate the driver and driven machinery to maintain the G dimension between the driver and driven hub ends.

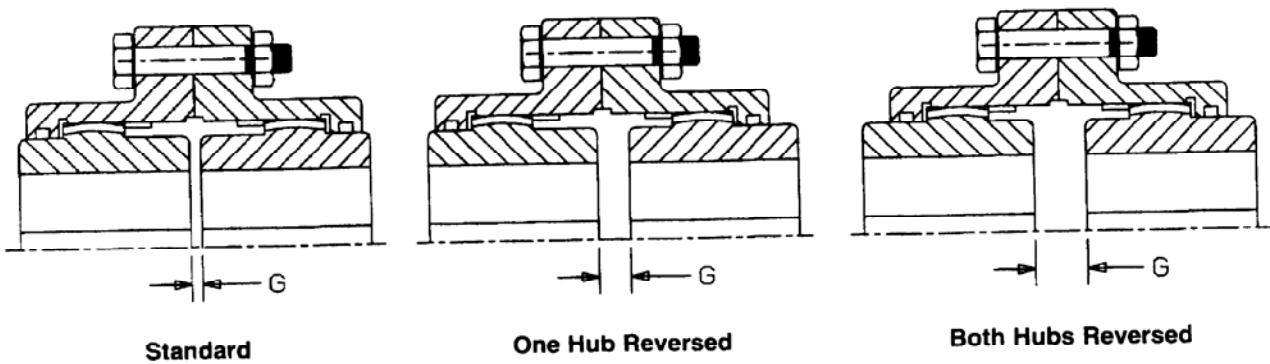

"G" Dimension	1	1-1/2	2	2-1/2	3	3-1/2	4
<b>Standard</b>	0.13	0.13	0.13	0.19	0.19	0.25	0.25
<b>One Hub Reversed</b>	0.44	0.38	0.81	0.97	0.84	0.81	1.94
<b>Both Hubs Reversed</b>	0.75	0.63	1.50	1.75	1.50	1.38	1.63

"G" Dimension	4-1/2	5	5-1/2	6	7	8	9
<b>Standard</b>	0.31	0.31	0.31	0.31	0.38	0.38	0.50
<b>One Hub Reversed</b>	1.53	1.72	1.53	1.72	1.69	1.13	1.25
<b>Both Hubs Reversed</b>	2.75	3.13	2.75	3.13	3.00	1.88	2.00

6. Using a dial indicator check the angular and parallel alignment of the hubs.

**Angular Method**

Attach the dial indicator to the base of one hub and the indicator needle against the face of the other hub. Rotate the hub on which the indicator base is attached, check the dial at 90° intervals. All four points should be the same reading on the dial.

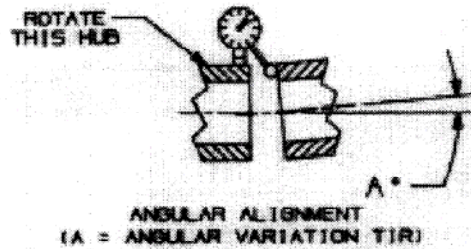

**Parallel Method**

Attach the dial indicator to the base of one hub and the indicator needle against the OD of the other hub. Rotate the hub on which the indicator base is attached, check the dial at 90° intervals. All four points should be the same reading on the dial.

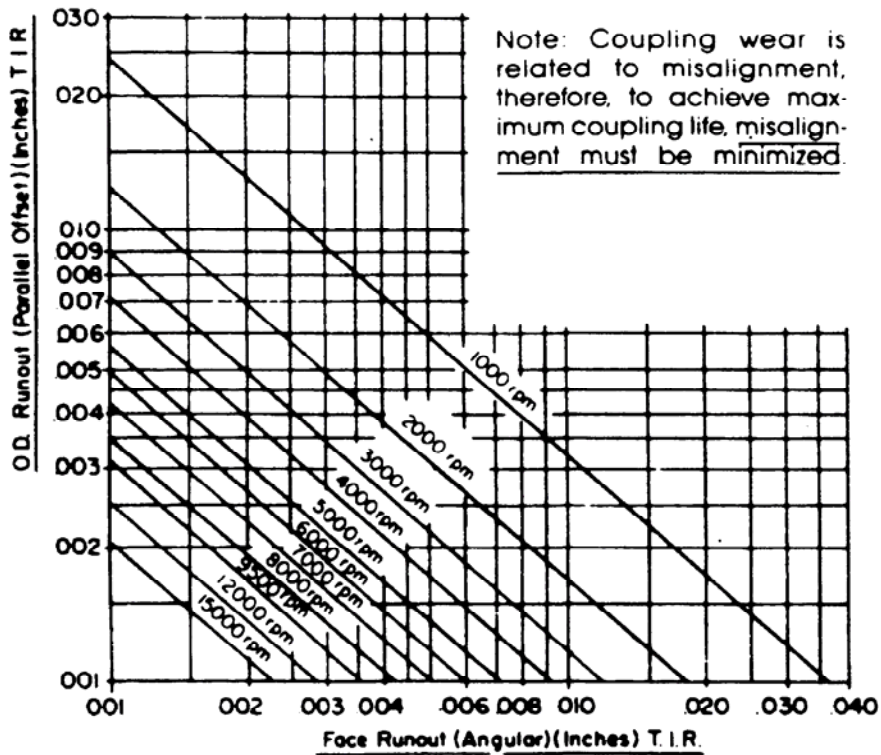
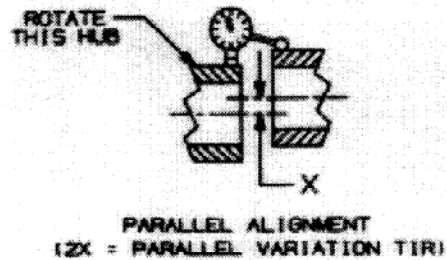

7. If the coupling is to be grease lubricated, coat all gear tooth areas with grease. Wood's suggest a grease complying to AGMA9001-B97.

8. Slide the sleeves over the hubs and install the gasket between the two sleeves.

9. Install and progressively tighten the bolts with a torque wrench until the proper torque value is met.

Torque (In Lbs)	1	1-1/2	2	2-1/2	3	3-1/2	4
Exposed Bolt	130	425	940	1750	1750	2650	2650
Shrouded Bolt	130	425	425	940	940	1750	1750

Torque (in Lbs)	4-1/2	5	5-1/2	6	7	8	9
Exposed Bolt	2650	3650	3650	3650	4850	6300	8300
Shrouded Bolt	1750	2650	2650	*	*	*	*

10. Remove lubrication plugs in each sleeve, add grease until filled.

*NOTE: If RPM is below minimum, use SAE 90 oil in lieu of grease.*

Size	1	1-1/2	2	2-1/2	3	3-1/2	4
Grease Cap. (oz.)	2	3	5	9	14	18	28
Minimum RPM	529	463	411	380	348	321	301

Size	4-1/2	5	5-1/2	6	7	8	9
Grease Cap. (oz.)	48	56	84	92	134	240	296
Minimum RPM	285	268	257	240	227	200	180

11. Install a proper coupling guard.

### Maintenance:

1. It is recommended that the coupling be completely flushed and relubricated after an initial break-in period of 3 million revolutions. (80 Hr @ 600 RPM)
2. Under normal industrial conditions the coupling should be disassembled, cleaned, and inspected every year. More severe applications may require more frequent inspection and relubrication.
3. During any inspection of the coupling when gear tooth wear is evident or the seal is leaking, it is recommended to replace the worn parts.
4. Upon reassembly after inspection always refer to the installation section for proper installation and wrench torques. Always regrease the coupling after inspection. Wood's recommends the use of grease which complies with AGMA9001-B97.

**TB WOOD'S INCORPORATED**  
**440 North Fifth Avenue**  
**Chambersburg, PA 17201**  
**Phone: 888-TBWOODS or Fax: 717-264-6420**